



Cooling Air Vendor Literature

Section 05-03-02

Komatsu has made every effort to make this manual as accurate as possible based on the information available at the time of publication and printing. Continuous improvement and advancement of product design may cause changes to machines, which may not have been included in this publication. Komatsu reserves the right to make changes and improvements at any time. To ensure the most current information, please contact your service center.

Vendor Literature

VL 13 - KLENZ™ Installation and Operations Manual

This Page Intentionally Left Blank



Installation & Operations Manual

LeTourneau CARTRIDGE FILTRATION SYSTEMS
Includes Installation, Operation, Service Instructions and Parts List

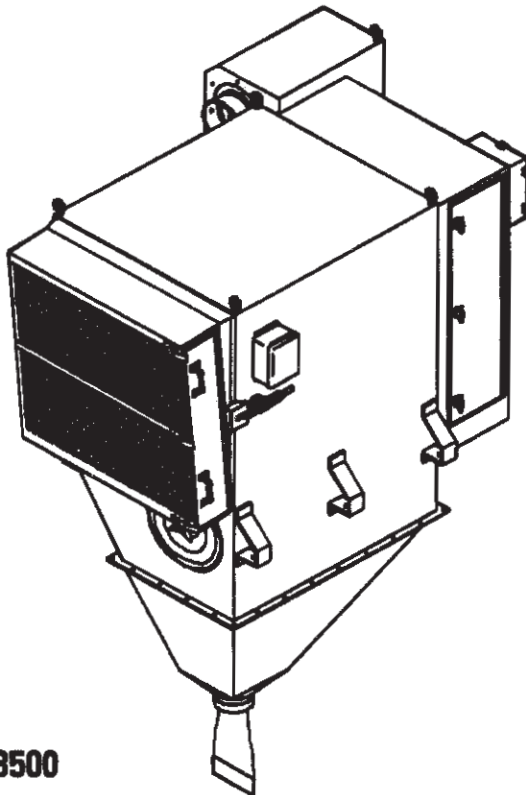

LT8500

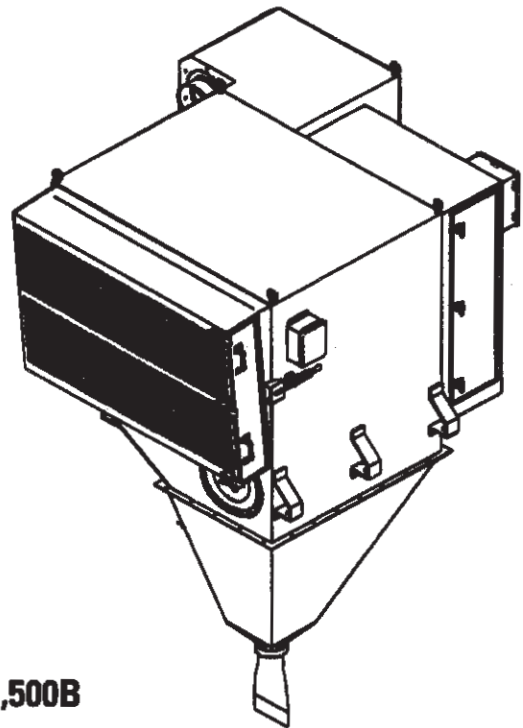

LT11,500B

IMPORTANT

This manual contains specific precautionary statements relative to worker safety in appropriate sections. Read this manual thoroughly and comply as directed. It is impossible to list all of the potential hazards of dust control equipment. It is imperative that use of the equipment be discussed with a LeTourneau representative. Personnel involved with the equipment or systems should be instructed to conduct themselves in a safe manner.



LeTourneau, Inc.

NOTE

Statements indicate precautions necessary to avoid potential equipment failure.

CAUTION

Statements indicate potential safety hazards.

CAUTION

Under no conditions should the machine operator be allowed to put lit cigarettes or any burning object into the hood or ducting of any dust control system.

Table of Contents

	Notes and Cautions	2
	Data Sheet	3
1.0	Introduction	4
1.1	Normal Operation	4
1.2	Filter Cleaning	5
2.0	Installation	5
2.1	Inspection	5
2.2	Ship Loose Items	5
2.3	Equipment/Tools Required	5
2.4	Assembly of Standard Equipment	5-6
2.4.1	Hopper Installation	6
2.4.2	Trickle Valve	9
2.4.3	Field Assembly of Yokes, Filters, and Covers	9
2.5	Electrical Installation	12
2.5.1	Electrical Operation	12
2.5.2	Solid-State Timer Specifications	12-13
2.6	Installation—Compressed Air Supply	13
3.0	Start-Up	13
4.0	Operating Adjustments	14
4.1	Operating Checks	14
5.0	Service	14
5.1	Filter Element Removal	15
5.2	Filter Element Installation	15
5.3	Original Equipment Filter Element	16
5.4	Compressed Air Components	16
5.5	Mist Eliminator Panel Cleaning	17
6.0	Replacement Parts List	18-33
	Parts Ordering Information	34

Figures

Figure 1	- Operational Schematic	4
Figure 2	- Hopper Installation	6
Figure 3	- Parts Drawing LT8500	7
Figure 4	- Parts Drawing LT11,500B	8
Figure 5	- Trickle Valve	9
Figure 6	- Yoke, Filter, and Cover Installation ..	10
Figure 7	- Solid-State Wiring Diagram	11
Figure 8	- Operation Logic Diagram	12
Figure 9	- Mist Eliminator	17

Parts Drawings

Parts Drawing 1	- LT8500 Cartridge Filter System	18
Parts Drawing 2	- Cover Knob Assembly LT8500	20
Parts Drawing 3	- Safety Filter Assembly	21
Parts Drawing 4	- Pressure Monitoring Assembly	22
Parts Drawing 5	- Solenoid Enclosure Replacement Parts Kit	24
Parts Drawing 6	- Manifold Assembly LT8500	25
Parts Drawing 7	- Control Box Assembly LT8500 & LT11,500B	26
Parts Drawing 8	- Trickle Valve	28
Parts Drawing 9	- LT11,500B Cartridge Filter System	29
Parts Drawing 10	- Access Cover Assembly Top/Bottom LT11,500	31
Parts Drawing 11	- Manifold Assembly LT11,500	32
Parts Drawing 12	- Inlet Door Assembly	33

Data Sheet

Customer Name	_____		
Address	_____		
Shipping Date	_____	Installation Date	_____
Model Number	_____	Serial Number	_____
Filter Medium	_____		
Accessories	_____		
Other	_____		

1.0 Introduction

The LeTourneau cartridge filter system provides clean air for the engine and for cooling the drive motors and electrical controls. In any environment, this system provides highly efficient, continuous air filtration.

The Ultra-Web® II filter elements are the heart of the cartridge filter system. These filter elements help ensure that clean air is supplied to the areas that need it.

Technical and field support are always available from your local LeTourneau distributors.

1.1 Normal Operation

During normal operation, dirty, and possibly moisture-laden, air enters the cartridge filter system through the side inlet area. It passes through the mist eliminator panels, where airborne water droplets are removed from the airstream. The air then moves through the filter cartridges, where dust is collected on the outside surfaces. The clean, filtered air flows through the center of the filter elements into the clean air plenum, where it exits through the clean air outlet.

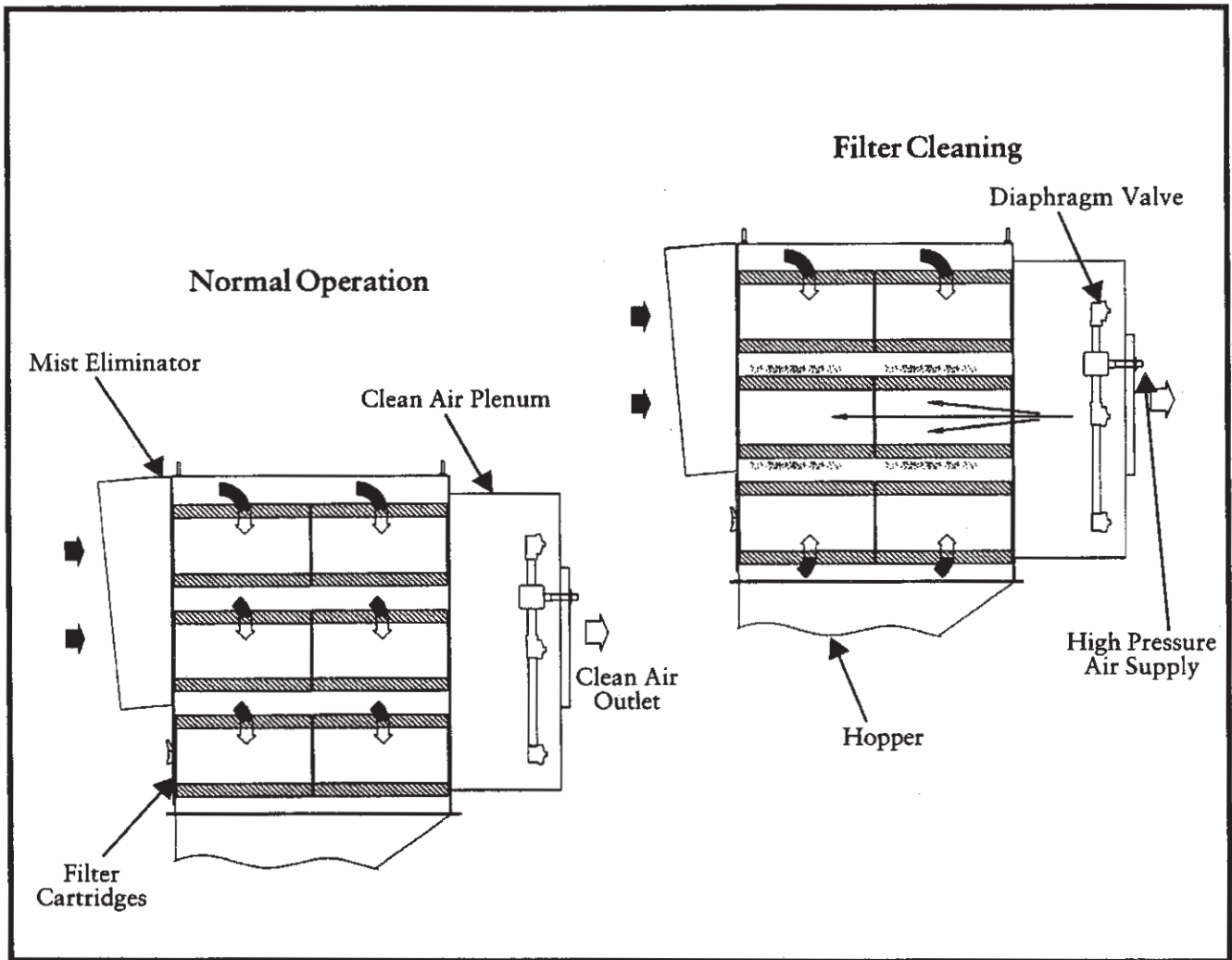

Figure 1
Operational Schematic

1.2 Filter Cleaning (See Figure 1 Operational Schematic)

Filter elements are cleaned continuously and sequentially. The result is that only one row (2 filter cartridges) may be off-line at any given time.

During the filter cleaning purge, the solid-state timer energizes a solenoid valve. The corresponding diaphragm valve sends a pulse of compressed air through the filter from the inside outward, removing the collected contaminants from the outside surfaces of the filter. The dust falls into the hopper and then drops out the trickle valve.

2.0 Installation

2.1 Inspection

The cartridge filter system is normally shipped by flat bed truck and should be checked for any damage that may have occurred en route. The damage should be noted and the carrier notified immediately.

2.2 Ship Loose Items

Items shipped loose with the cartridge filter system may include:

- Hopper
- Trickle Valve
- Hardware/Sealant

2.3 Equipment/Tools Required

The following is a list of typical tools and equipment required to install and assemble the unit:

- Crane/Lift Truck
- Slings/Spreader Bars/Clevis Pins
- Drift Pins
- Clamps
- Screwdrivers
- Pipe Wrenches
- Socket Wrenches
- End Wrenches
- Large Crescent Wrench
- Drill and Drill Bits
- Pipe Sealant

CAUTION

A crane must be used to move the collector into position.

2.4 Assembly of Standard Equipment

NOTE

A crane is recommended for the unloading, assembly and installation of the cartridge filter system.

CAUTION

Connect the lifting sling to a minimum of four (4) cabinet lifting eyes. Distribute loads evenly. Use clevises, not hooks, on the lifting sling. Use spread bars on the lifting sling.

Remove all crating and strapping from the unit. Remove all miscellaneous parts (bolts, nuts, etc.) before lifting the unit off the truck. Check the parts received against the packing slips. If there are parts missing, the carrier and your local LeTourneau representative should be notified immediately.

NOTE

Each item to be attached to your collector is accompanied by a drawing that shows the attachment process. Refer to both the drawing and this manual when assembling the collector.

2.4.1 Hopper Installation (See Figure 2 Hopper Installation)

1. Stand the hopper up on the discharge end (hopper outlet).
2. Apply sealant to the top flange all around the inside of the bolt pattern.
3. Lift the collector from the truck. Position the collector over the hopper and lower slowly.
4. A set of drift pins will be helpful in prelocating the holes for assembly.
5. Lower the collector over the hopper flange enough to start attaching the hardware, being careful not to support the collector with the hopper. Assemble them together with 3/8" - 16 x 1-1/4" bolts, flat washers and nuts. Tighten all hardware securely.

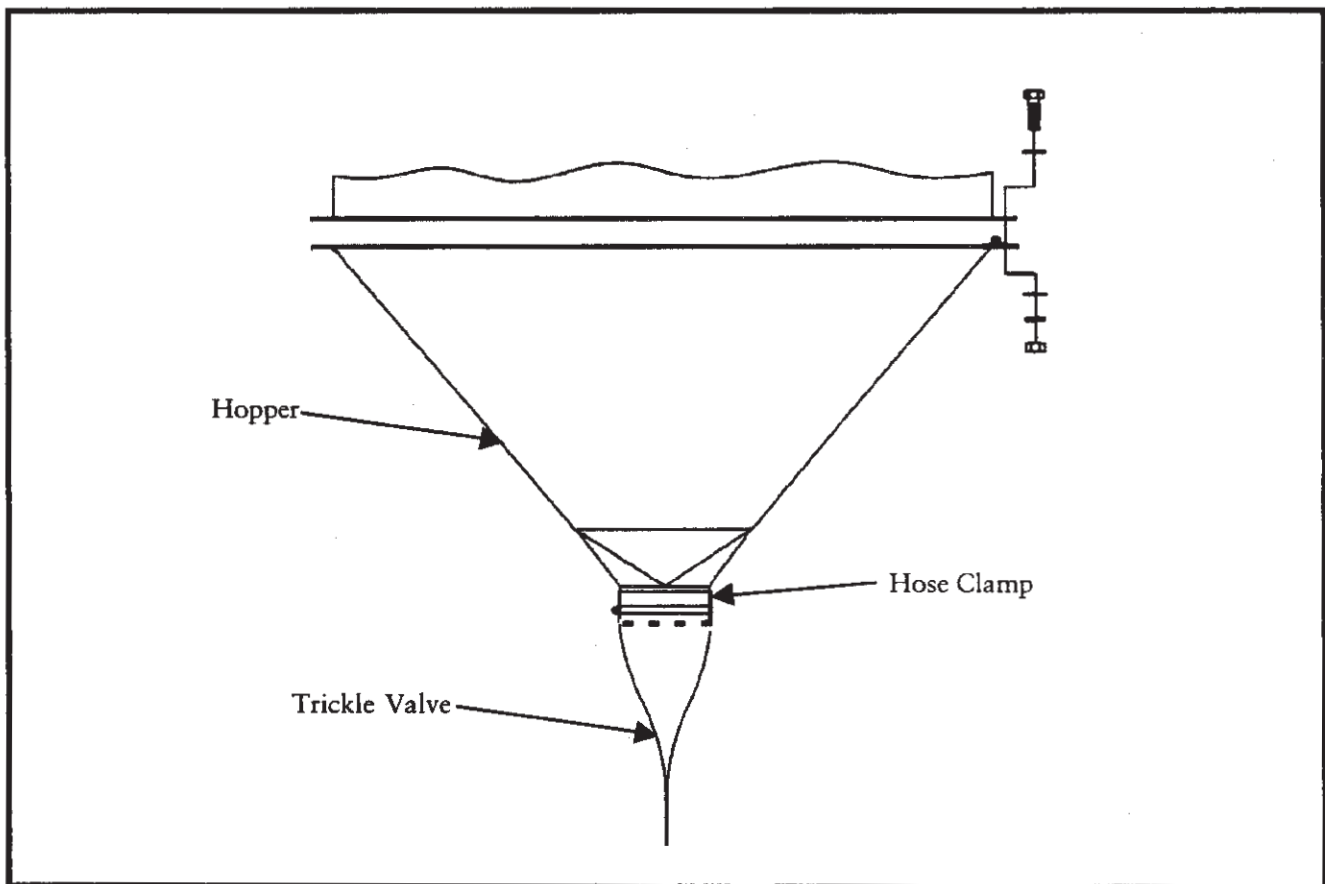

Figure 2
Hopper Installation

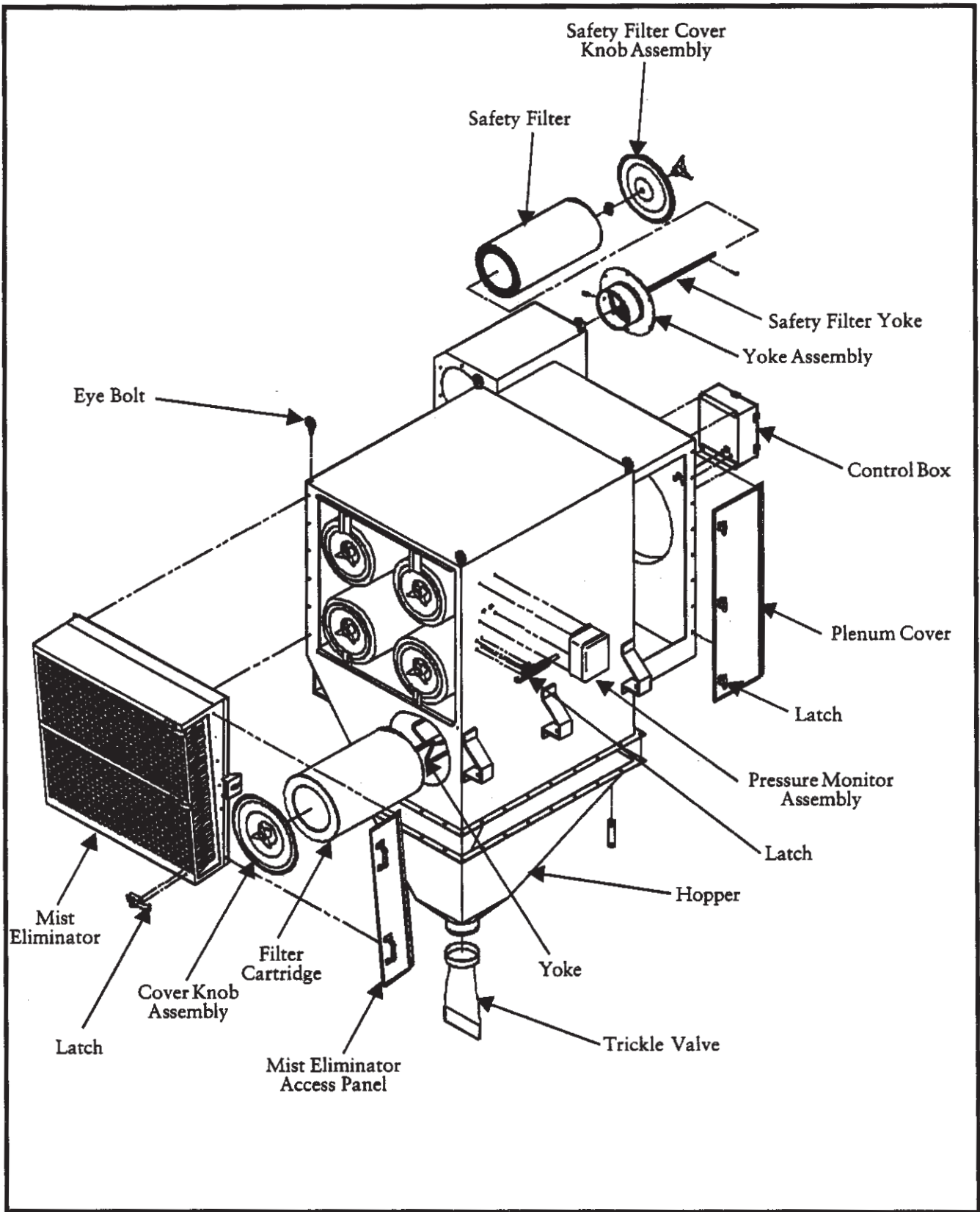

Figure 3
Parts Drawing LT8500

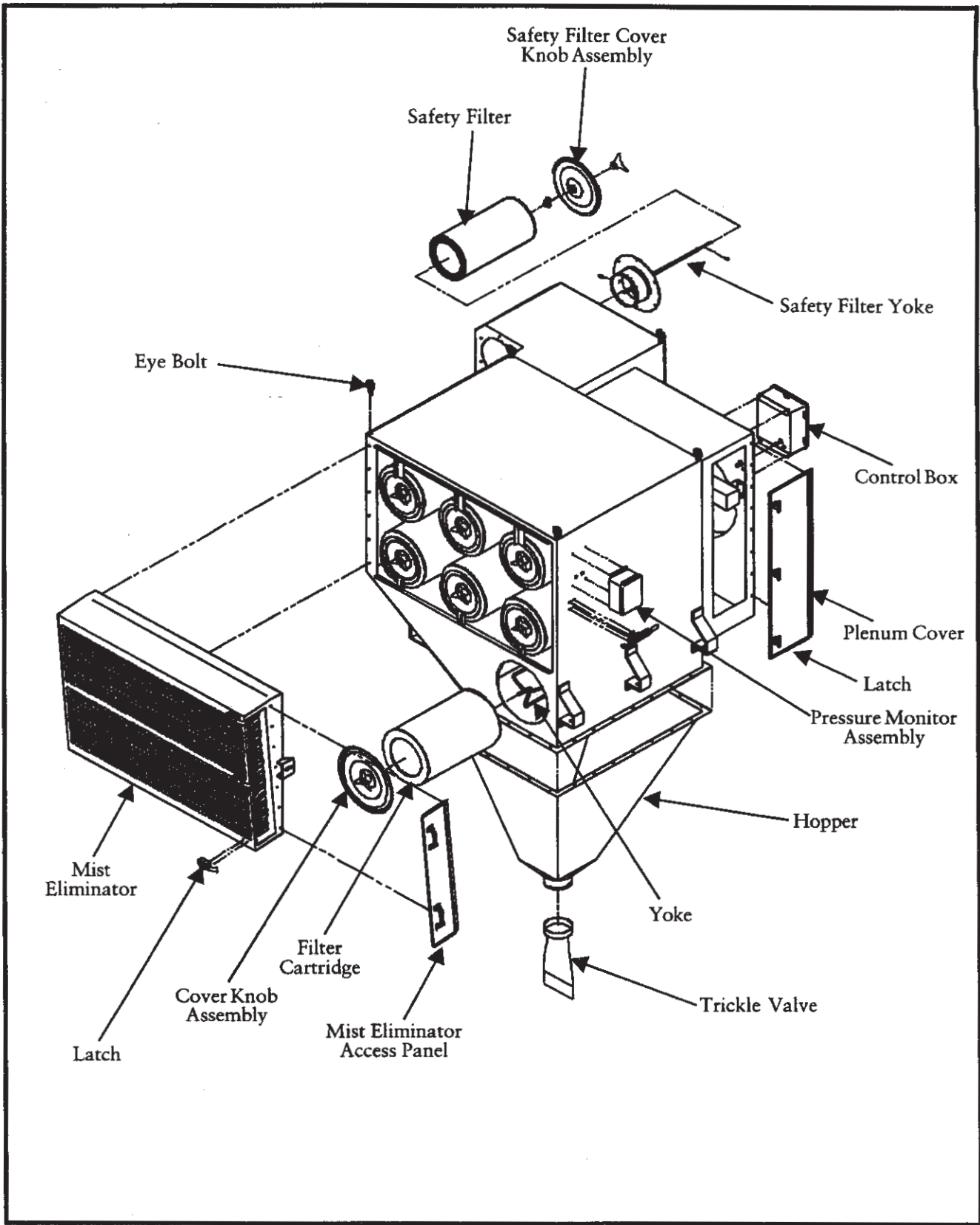

Figure 4
Parts Drawing LT11,500

2.4.2 Trickle Valve (See Figure 5 Trickle Valve)

The trickle valve and adapter is specifically designed to dump product from the collector onto the ground. When either the pulse pressure occurs or the weight builds in the trickle valve, the valve opens, then recloses after dumping the product.

1. Attach the trickle valve to the hopper using the hose clamp, as shown in Figure 5 Trickle Valve.

2.4.3 Field Assembly of Yokes, Filters, and Covers

Installing requires two people.

1. The best method is to start from the top hole and move downward. Install the yoke (3 rod end first) into the dirty air chamber through the front panel. The yoke must be positioned as shown in Figure 6 Yoke, Filter, and Cover Installation. One person should hold

the yoke in place in the filter section, while another installs the 5/16" washers and 3/8" hex nuts onto the rod ends from the clean air chamber. Do not tighten the hardware at this time.

2. The stud on the front end of the yoke must be centered in the front access opening side to side and adjusted 1/4" above centerline. This adjustment is made by moving the hex jam nut against the element panel. Once the yoke is centered, tighten the three hex nuts on the back side of the element panel in the clean air chamber. Repeat the procedure on all yokes.
3. Install the gasketed end of the filter elements into the collector first. Install the covers onto the filters and hand-tighten all covers. Make sure the covers are securely fastened.

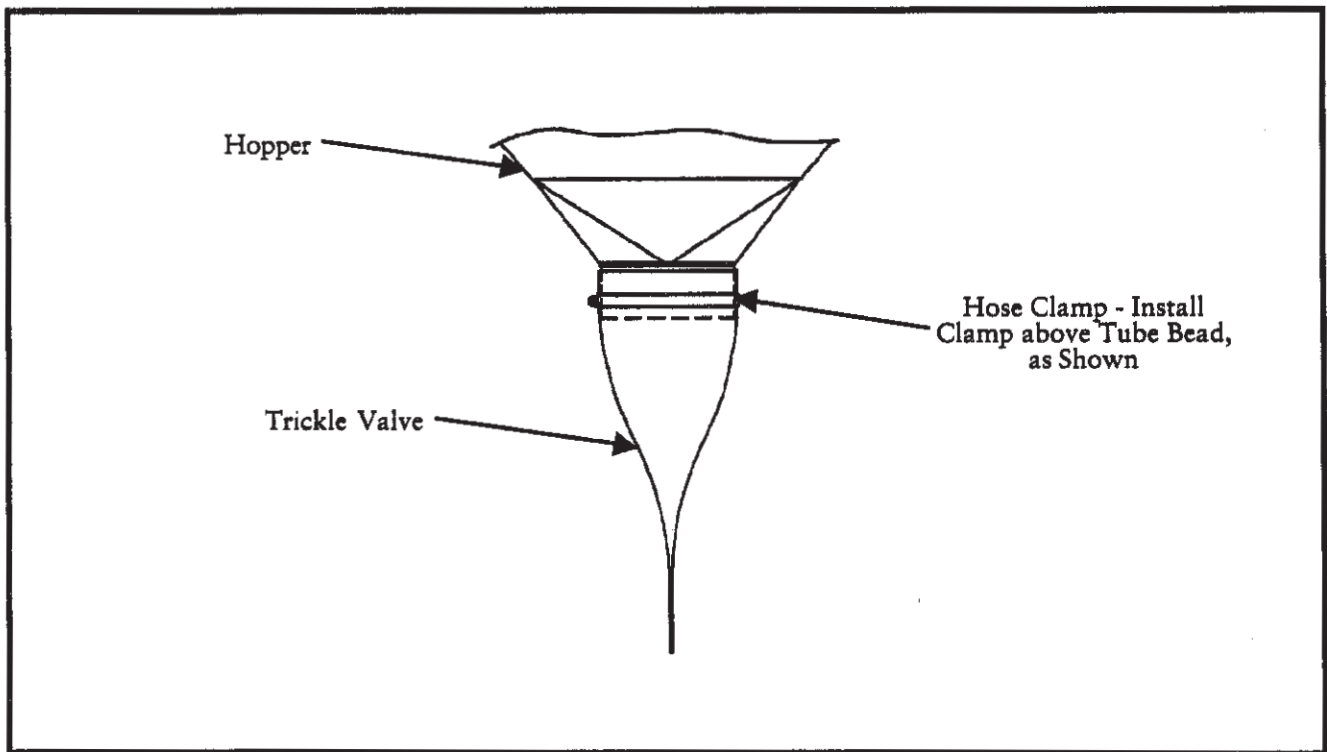
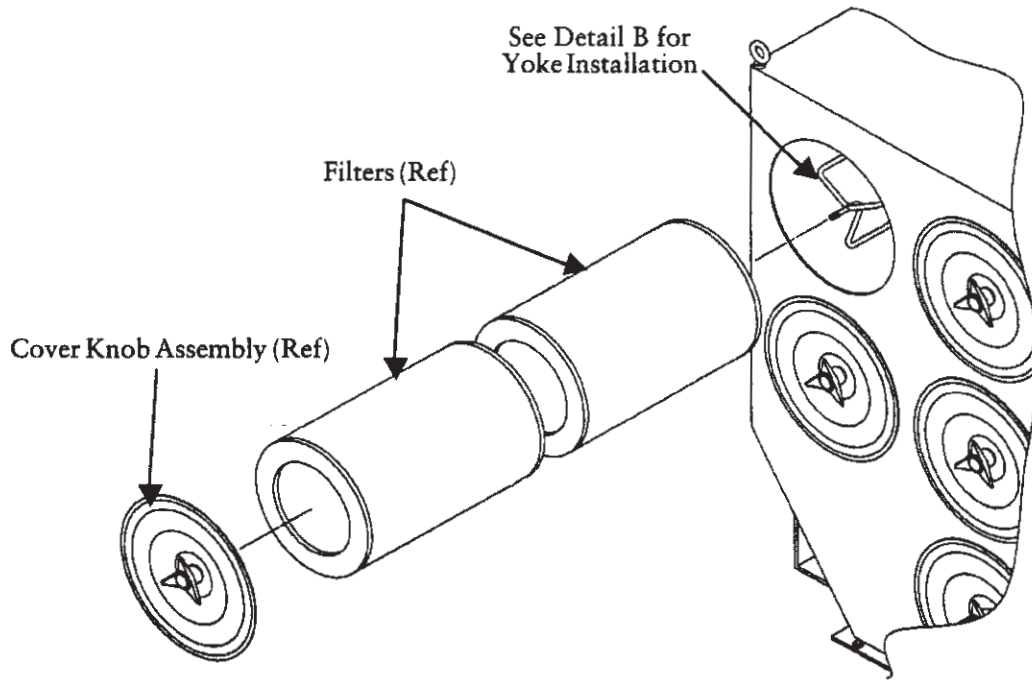
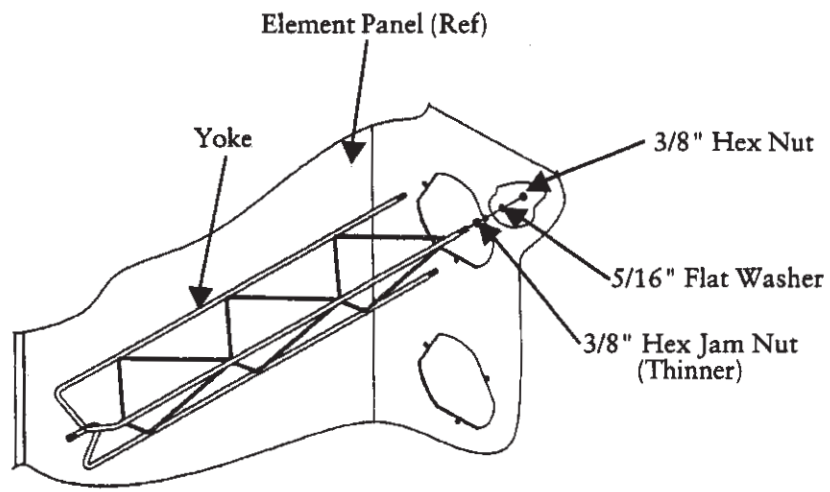

Figure 5
Trickle Valve



Detail A



Detail B

Figure 6
Yoke, Filter, and Cover Installation

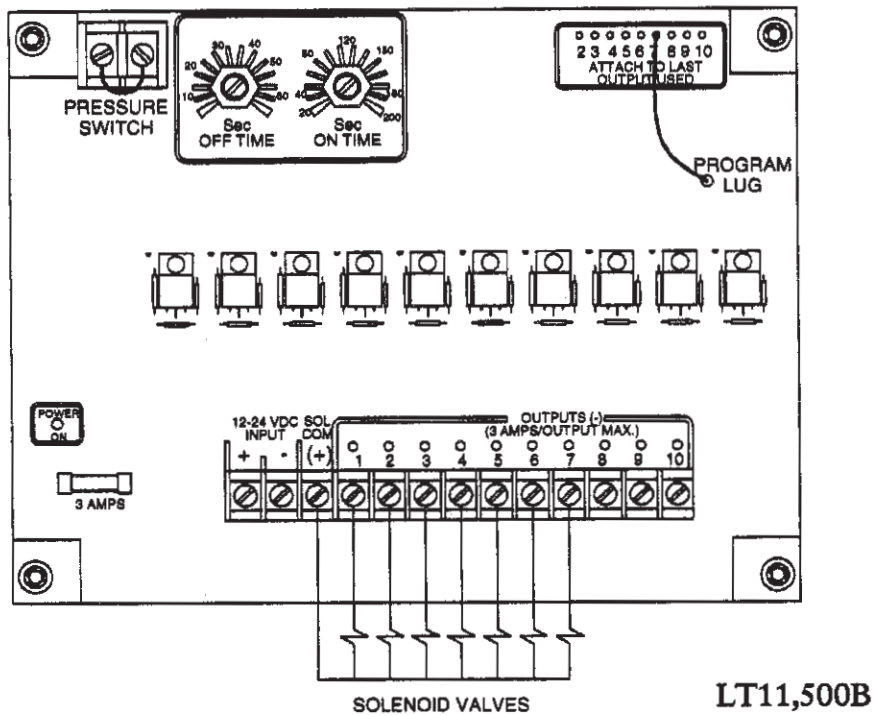
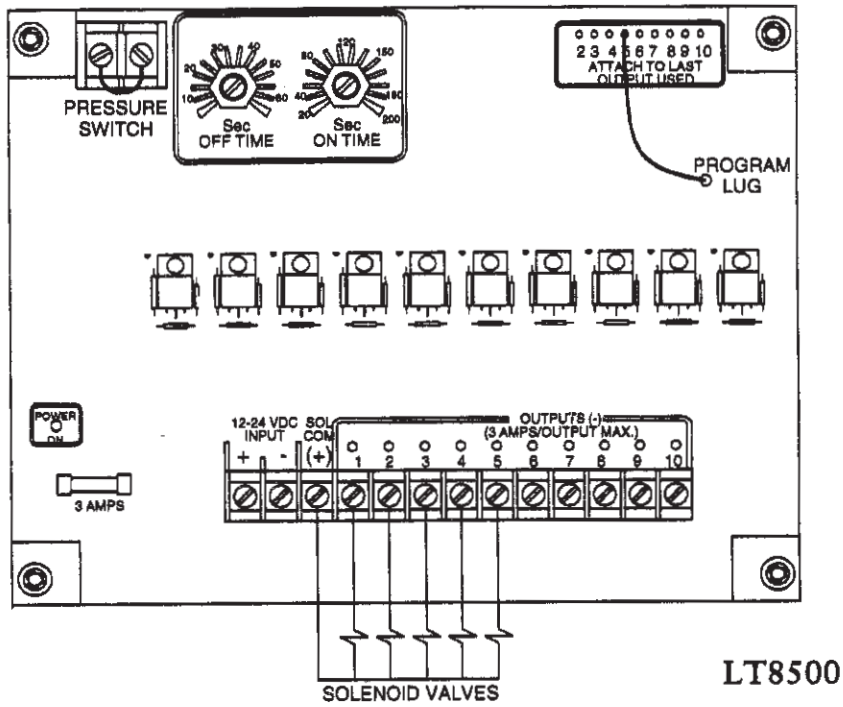

Figure 7
Solid-State Control Timer Wiring Diagram

2.5 Electrical Installation
 (See Figure 7 Solid-State Control Timer
 Wiring Diagram)

NOTE

All electrical work must be done by a qualified electrician.

CAUTION

Disconnect electrical power before servicing any electrical component.

2.5.1 Electrical Operation (See Figure 7
 Solid-State Control Timer
 Wiring Diagram)

Each cartridge filter system comes equipped with 24 volt DC solenoid valves that control the pulse cleaning valves, which clean the Ultra-Web filter elements. The solenoids are supplied in a NEMA 4 enclosure that is mounted on the compressed air manifold.

The solenoids are connected electrically to the solid state control timer. If not wired properly, filter life and proper cleaning will be affected.

2.5.2 Solid-State Control Timer Specifications
 (See Figure 7 Solid-State Control Timer
 Wiring Diagram)

NOTE

Solid-state control timer requires a 12-24 VDC control circuit.

The timer is factory-adjusted at 100 milliseconds (1/10 second) pulse time and a 60 second duration (elapsed time) between pulses.

Input power to the solid-state electrical control timer is applied to the positive terminal on the timer control circuit board. Upon start-up, power is supplied to the control board and the preset OFF time is initiated. At the end of the OFF time, the control board timer will energize a corresponding solenoid valve to provide the ON time cleaning pulse for one filter element and then step to the next filter element.

This cycle is continuous while the unit is running. The control board program pin selection should be set on pin 5 for the LT8000 or pin 7 for the LT 11,500 (see Figure 7 Solid-State Control Timer Wiring Diagram).

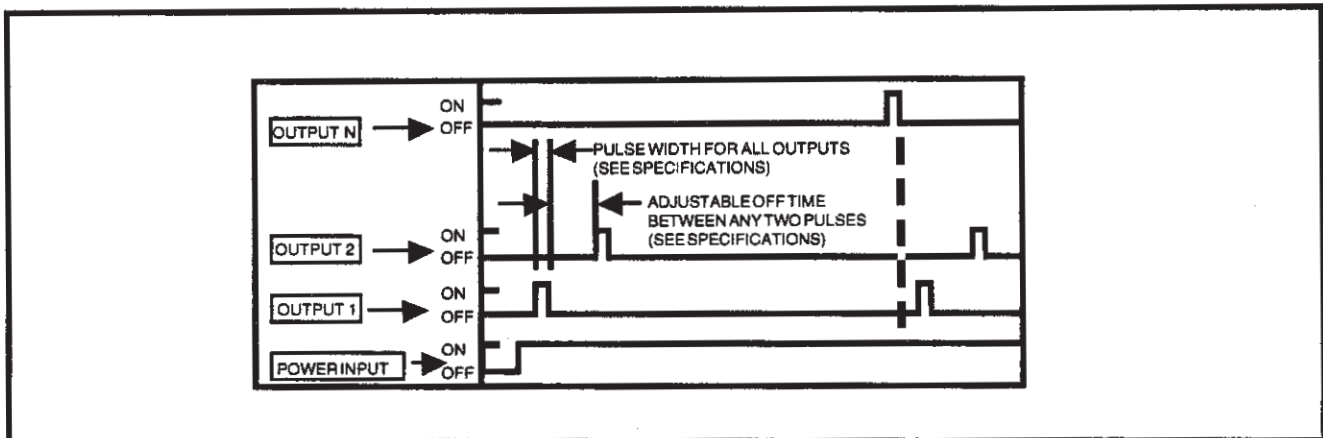

Figure 8
Operating Logic Diagram

NOTE

Do not adjust ON time unless the proper test equipment is used. Too much or too little ON time can cause shortened filter element life. Consult with your LeTourneau representative.

Input: 24 VDC

Operating Temperature Range: -20° to +130°F

Solenoid Valves: 24 VDC

2.6 Installation — Compressed Air Supply

NOTE

- It is important that the compressed air supply be both oil and moisture free. Contamination in the compressed air that is used to clean filter elements will result in poor cleaning or cleaning valve failure and poor collector performance.
- Purge compressed air lines to remove debris before connecting to the compressed air manifold on the cartridge filter system.

CAUTION

Shut off and bleed off compressed air supply before doing any service work.

Remove the plastic pipe cap from the inlet to the compressed air manifold and connect the compressed air supply line. Use thread-sealing tape or pipe sealant on all compressed air connections.

The compressed air shut-off valve, bleed-type regulator with gage and automatic condensate valve should be installed in the compressed air supply line. Locate these components for convenient service, start-up and shutdown of the cartridge filter system.

Be sure that all compressed air components are adequately sized to meet the maximum system requirements of 1.1 scf per pulse at 90 psig supply pressure.

3.0 Start-Up

1. Turn on the compressed air supply to the cartridge filter system compressed air manifold. Adjust to 90 psig of pressure with the compressed air regulator. Pressure of 90 to 100 psig is the most typical setting for satisfactory cleaning performance (see Section 4.0 Operating Adjustments). The lower the compressed air setting, the less the pulse valve air consumption will be.

NOTE

Make sure the hopper discharge opening is closed. Too much airflow to the blower fan will cause failure.

4.0 Operating Adjustments

The compressed air is recommended to be set at 90 psig. The control timer is factory set to clean one row of elements every 10 seconds.

If the filter elements are operating at a higher than design ΔP^* , it may be lowered by increasing the frequency of cleaning. The minimum OFF time or elapsed time, between pulses is three seconds. Additional cleaning energy may be obtained by adjusting the pressure upward to a maximum of 100 psig.

NOTE

- Do not increase compressed air pressure beyond 100 psig, as component damage may result.
- Do not increase or decrease the pulse ON time on the solid-state control timer. Longer or shorter pulse ON times do not aid in the cleaning of filter elements. They merely waste compressed air and cause shortened filter element life.

Pulse ON time can be checked or adjusted by consulting your local LeTourneau representative.

At a low operating ΔP , you may want to raise to a higher pressure drop point level by increasing the OFF time between pulses on the solid state control board. This will greatly reduce your compressed air consumption.

* ΔP = Pressure drop across filter elements in inches water gage.

4.1 Operating Checks

Monitor filter element pressure drop. Equilibrium pressure drop (stabilized ΔP) is generally 3 to 4 inches water gage on a Magnehelic for seasoned filters, but 1 to 6 inches water gage is considered normal.

5.0 Service

CAUTION

- Disconnect electrical power before servicing any electrical components.
- Shut off and bleed compressed air supply before servicing any compressed air components.
- No welding should be performed inside unit without fire protection.

5.1 Filter Element Removal (See Figure 6 Yoke, Filter, and Cover Installation)

1. When changing the filter elements, start at the top access ports of the unit first, so that the dust that falls down into the hopper area does not have open access ports below.
2. Remove access covers by unscrewing the knobs counterclockwise by hand. Set access covers aside.
3. Move the filters to break the gasket seals between the filter element and the element panel sealing surfaces.
4. Rotate the element slowly 1/2 turn to dump any loose build-up of dust off of the top of the filter element.
5. Slide the filter element along the suspension yoke and out of the front of the collector access port.

NOTE

- Do not drop or rap the element on any hard surface. Damage to the filter element will occur, resulting in leakage.
- It is necessary to clean the dust off of the element support panel all around the opening and off of each filter end cap and the access cover to ensure a positive seal of the filter gasket.

5.2 Filter Element Installation (See Figure 6 Yoke, Filter, and Cover Installation)

NOTE

- The filter element gasket end on all the filters must be inserted first, facing inward toward the clean air section or leakage will occur.
- Access cover knobs must be securely tightened. Lack of compression of the filter gaskets can cause leakage.

1. Slide the new Ultra-Web filter elements onto each suspension yoke.
2. Wipe off access cover gaskets and re-install the access covers by turning the knob clockwise onto the suspension yoke threads. Tighten securely by hand.
3. The system is now ready to start up. Turn on the compressed air supply before starting.

5.3 Safety Filter Element Installation

1. Slide the new safety filter elements onto each suspension yoke.
2. Tighten filter retention knob until the hole in the yoke is aligned with the notch in the retention knob.
3. Place the cotter pin through the notch and hole.
4. Wipe off access cover gaskets and re-install the access covers by turning the knob clockwise onto the suspension yoke threads. Tighten securely by hand.
5. The system is now ready to start up. Turn on the compressed air supply before starting.

5.4 Original Equipment Filter Element (See Replacement Parts List)

The Ultra-Web filter element is the only replacement filter that will provide the high level of performance that you need in the cartridge filter system.

5.4 Compressed Air Components

CAUTION

Shut off and bleed off compressed air supply before doing any service work.

1. Periodically check the compressed air components. Service them by installing new compressed air filters and draining any moisture off, following manufacturer's instructions.
2. Check the compressed air manifold for contamination, oil and/or water. Clean or drain if necessary.
3. With the compressed air supply turned on, check the cleaning valves, solenoid valves and tubing for any leakage. Replace any components that are leaking compressed air (reference the Replacement Parts List).

5.5 Mist Eliminator Panel Cleaning

After several hours of operation in wet conditions, the mist eliminator panels may require cleaning. To properly clean the mist eliminator panels, they must be removed. Do not attempt to clean the panels inside the unit, as damage to the filter elements may result. Once removed, the panels can be cleaned by spraying them off with a low pressure hose. Never use high pressure, as damage to the panels may result. Once cleaned, the panels should be dried with compressed air and reinstalled.

1. Remove the mist eliminator panels, by opening the access door. The access door is secured by quick release latches. Open the latches and open the door.
2. Slide the panels through the guides out the side of the unit. Take note of the panels' orientation to make sure they are reinstalled the same way.
3. Reinstall panels by sliding them into the guides. Make sure the sides overlap to prevent any openings to the filter chamber (see Figure 9 Mist Eliminator).
4. Close and latch the access cover, sealing the mist eliminator section.

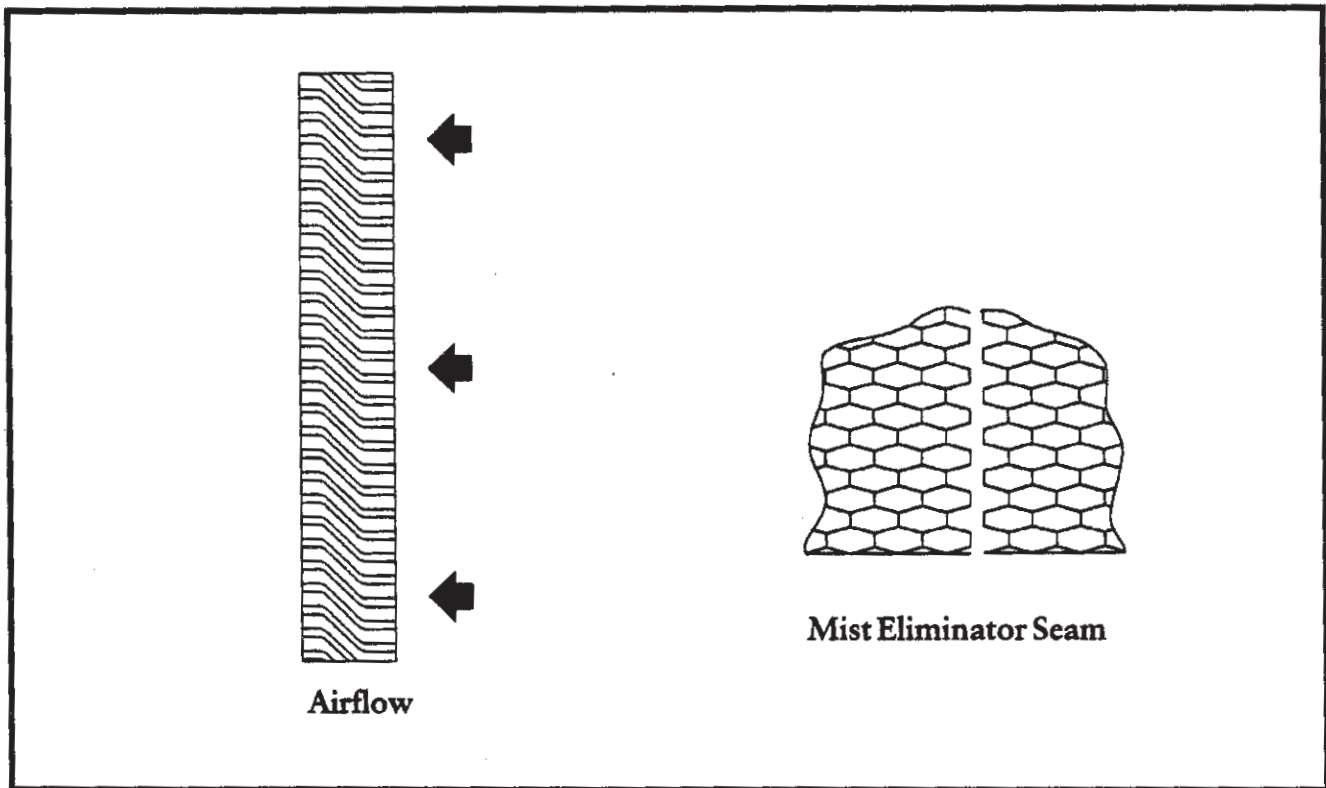
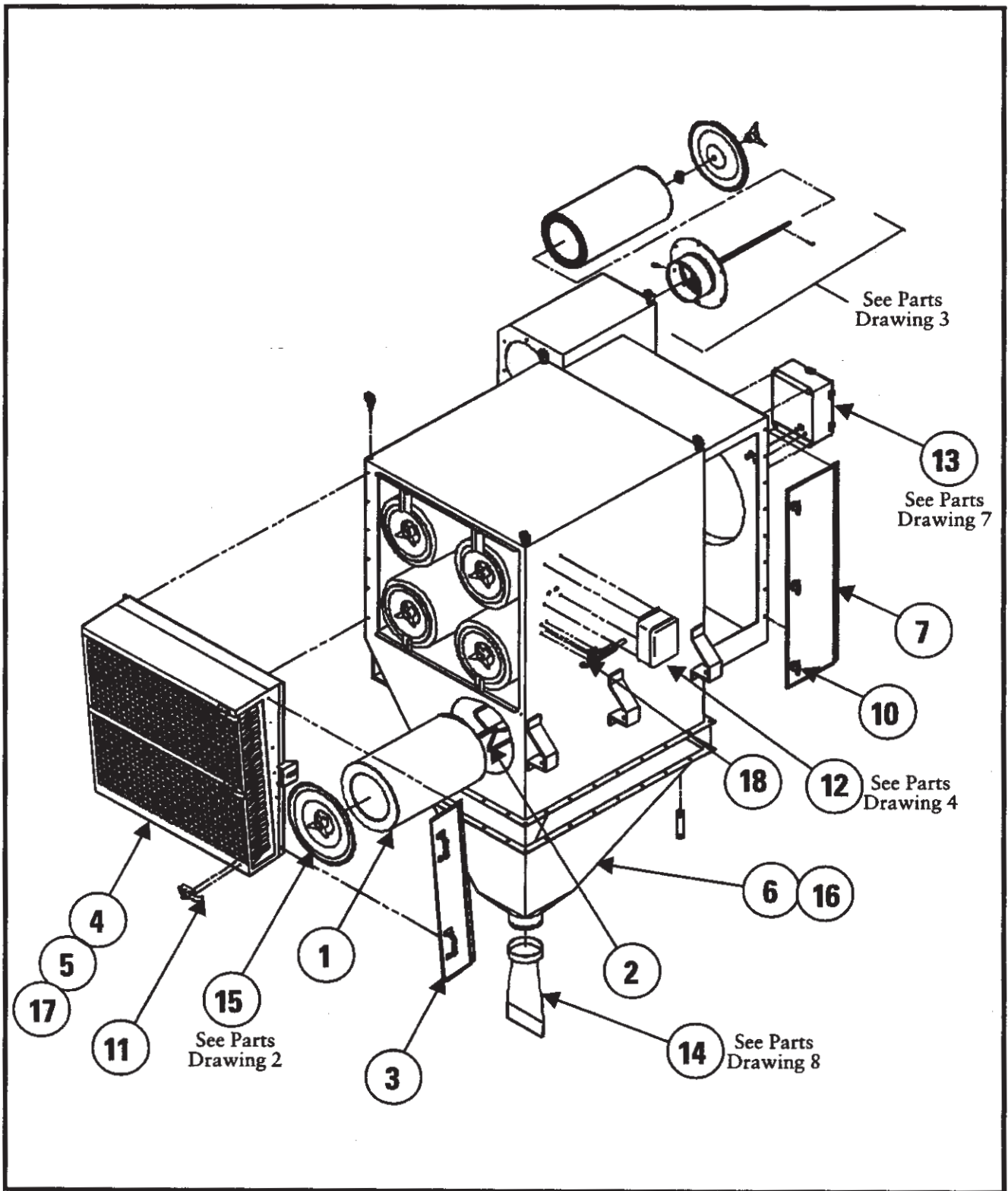

Figure 9
Mist Eliminator

6.0 Replacement Parts List



Parts Drawing 1
LT8500 Cartridge Filter System

Replacement Parts List

Parts Dwg. No.	Ref No.	Part No.	Description	Qty.
----------------------	------------	-------------	-------------	------

1	1	421-9820	Filter Element Blue Ultra-Web® II.....	All
	2	424-1610	Yoke Weld	All
	3	423-4050	Weld Access Panel Mist Eliminator	LT8500
	4	423-1315	Drift Eliminator Intlk 25.25 x 48.00	LT8500
	5	421-9821	Drift Eliminator Intlk 19.25 x 48.00	LT8500
	6	424-1607	Hopper Weld	LT8500
	7	423-4054	Cover Weld CA Plenum with Holes	LT8500
	8	N.P.N.	Bolt Eye Shldr 1/2-13 x 1.50	All
	9	N.P.N.	Nipple Galv 1" NPT x 5.00 Lg	LT8500
	10	423-4055	Latch Vise Action	All
	11	423-4056	Latch Over Center	LT8500
	12	423-4057	Pressure Monitoring Assembly	LT8500
	13	423-4058	Control Box Assembly	LT8500
	14	423-4059	Trickle Valve	All
	15	423-4060	Cover Knob Assembly	LT8500
	16	424-1608	Hopper Pack with Valve and Hardware	LT8500
	17	424-1609	Inlet Door Assembly	LT8500
	18	424-4064	Clamp, Modified	LT8500

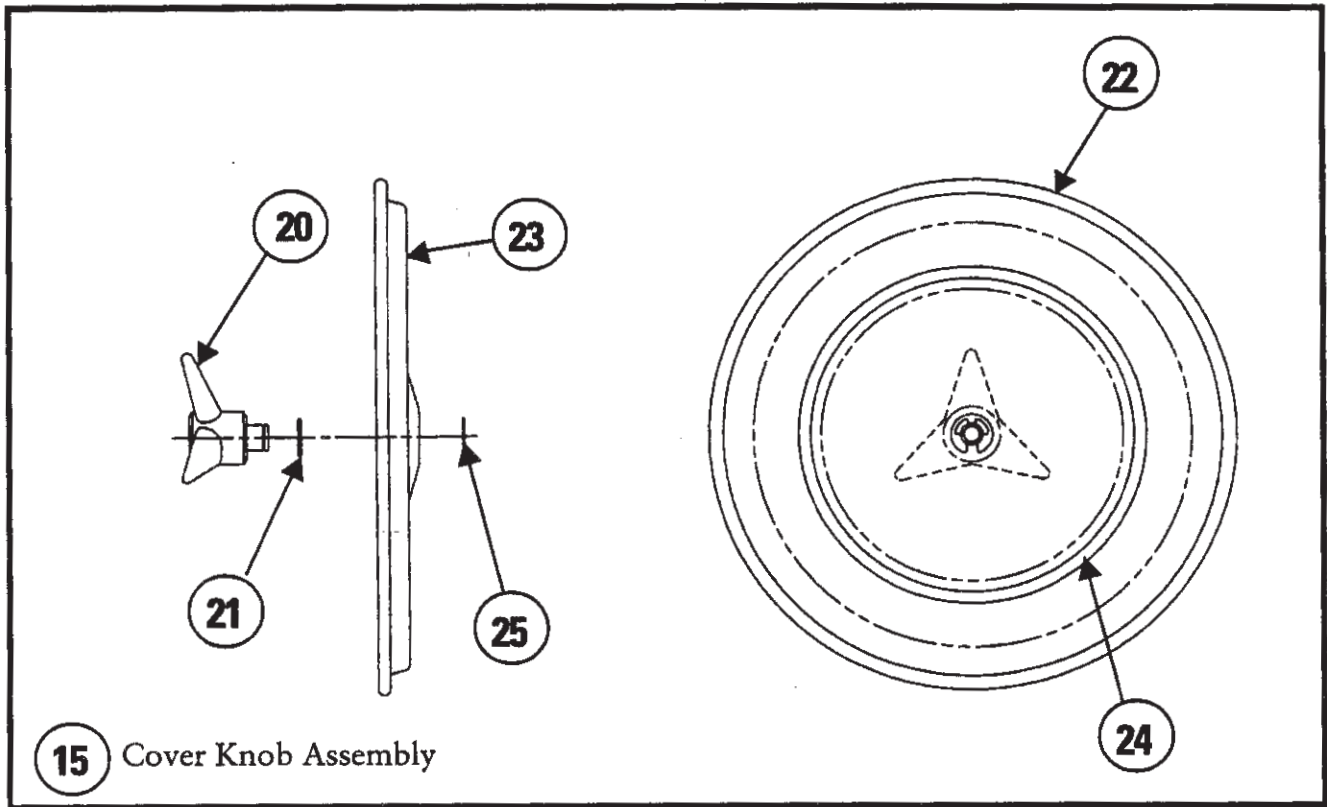

**Parts Drawing 2
Cover Knob Assembly LT8500**

Replacement Parts List

Ref. No.	Part No.	Description	Model
15	423-4060	Cover Knob Assembly	LT8500
20	422-3086	Knob 3 Lobe	All
21	423-4067	Gasket Washer .81" ID	All
22	423-4068	Gasket Cover Filter Access	LT8500
23	423-4069	Cover, Element Filter Access	LT8500
24	423-4070	Gasket 3/8" x 1/2" - 10.12" ID	All
25	423-4071	Clip .668" ID	All

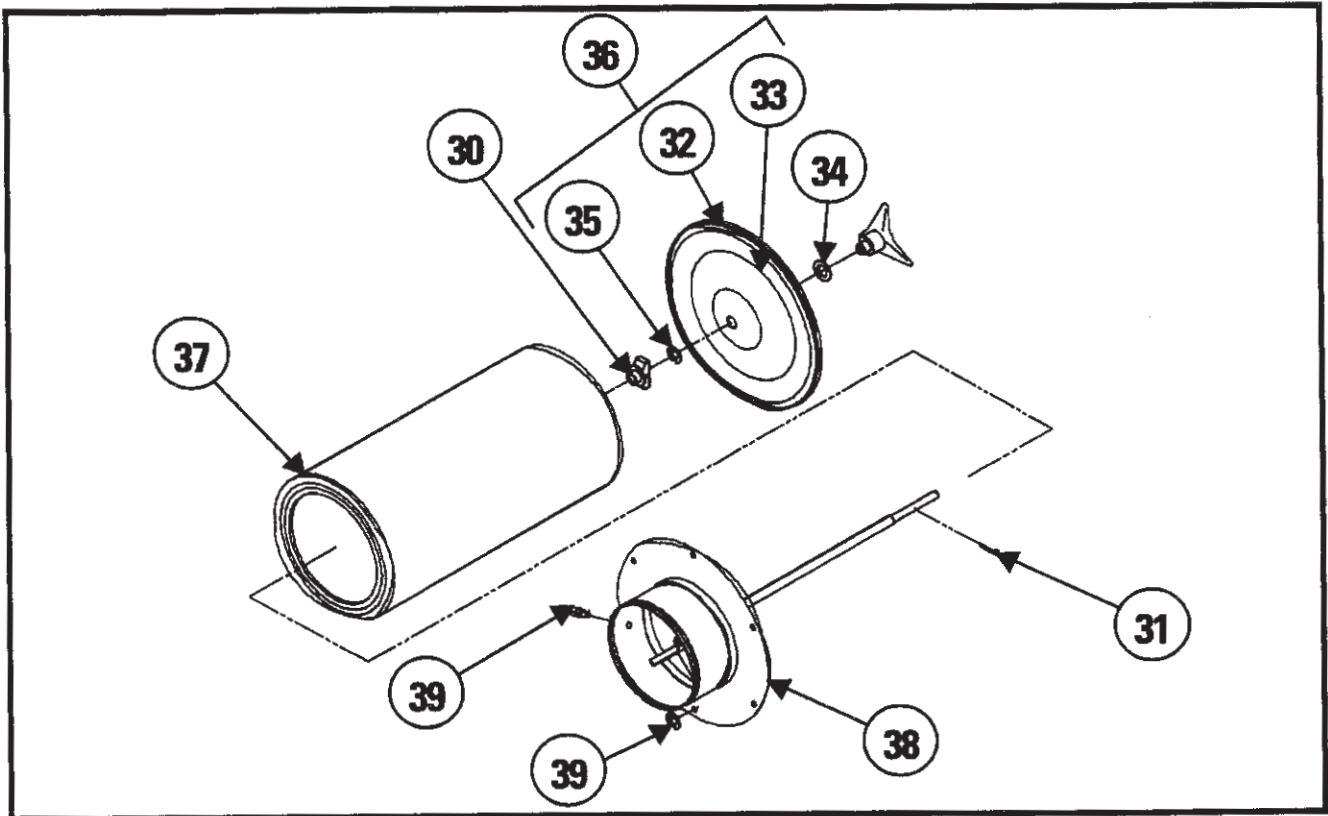

**Parts Drawing 3
Safety Filter Assembly**

Replacement Parts List

Ref. No.	Part No.	Description	Model
30	423-3235	Nut Indicator	All
31	423-3236	Pin	All
32	424-1606	Gasket Filter Access 14.00	All
33	424-1605	Cover End Yoke 14.00	All
34	423-4067	Gasket Washer, Flat	All
35	423-4071	Clip	All
36	423-3233	Cover Knob Assembly 14"	All
37	423-3232	Element Assembly 8"	All with 8" Flange
37	424-1604	Element Assembly 10"	LT11,500B with 10" Flange
38	423-3234	8" Flange Assembly	All with 8" Flange
38	424-1602	10" Flange Assembly	LT11,500B with 10" Flange
39	416-4372	Safety Adapter	All
40	424-1603	Nut, Hex	All

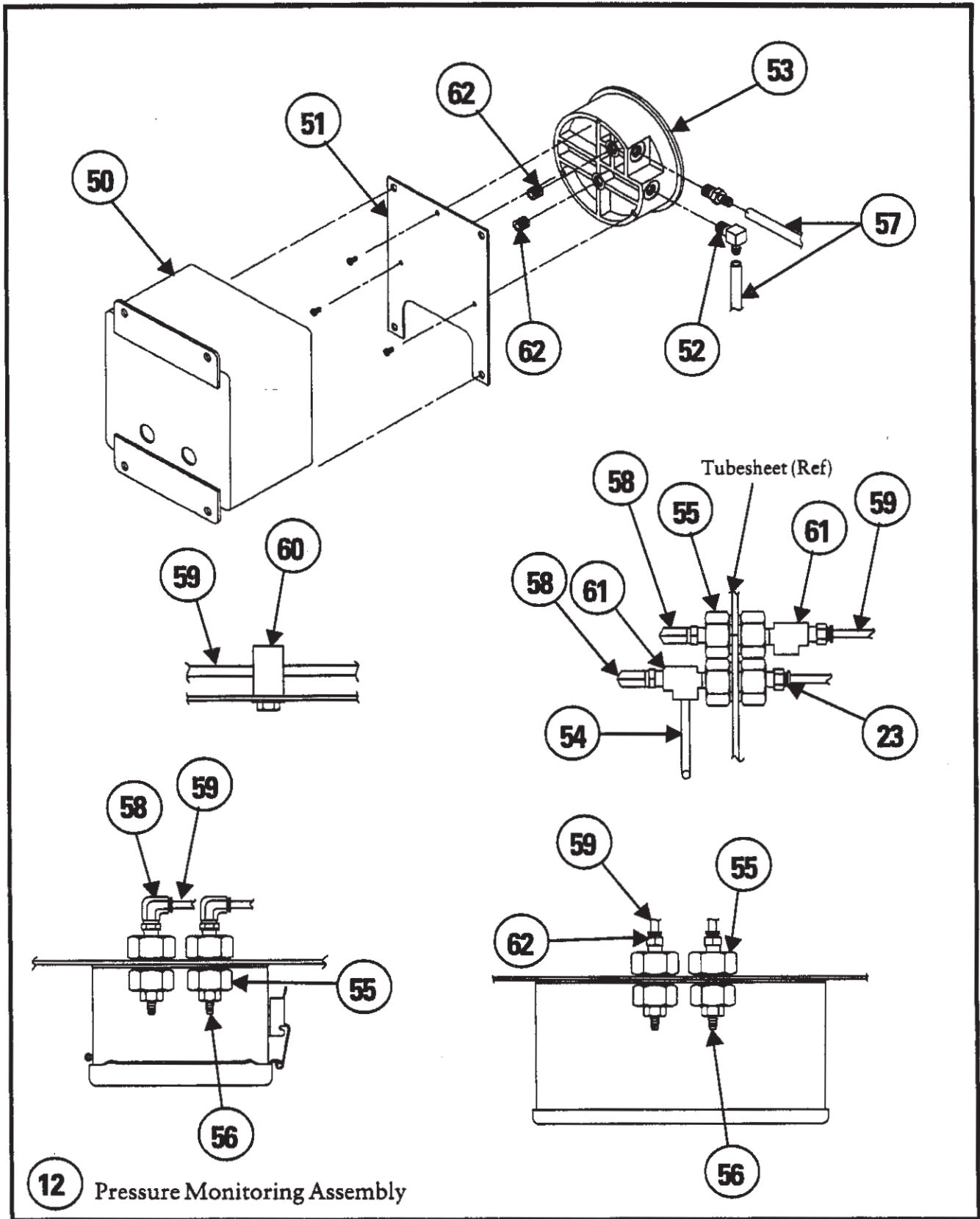

Parts Drawing 4
Pressure Monitoring Assembly

Replacement Parts List

Parts Dwg. No.	Ref No.	Part No.	Description	Qty.
----------------------	------------	-------------	-------------	------

	12	423-4057	Pressure Monitoring Assembly LT8000	LT8000
	12	423-4061	Pressure Monitoring Assembly LT11,500	LT11,500
4	50	N.P.N.	Enclosure, Modified	All
	51	N.P.N.	Sub Panel Modified	All
	52	N.P.N.	Elbow 90° Plastic Male 1/8" NPT	All
	53	N.P.N.	Gage Pressure Magnehelic*	All
	54	N.P.N.	Static Pressure Tip T Brass	All
	55	N.P.N.	Anchor Coupling 1/8 NPT	All
	56	N.P.N.	Adapter Brass 1/8" NPT	All
	57	N.P.N.	Tubing Plastic 3/16 ID	All
	58	N.P.N.	Connector Elbow 1/4 OD Plastic x 1/8 NPT	All
	59	N.P.N.	Tubing Poly 1/4 OD	All
	60	N.P.N.	Clamp Double Line Vbr Dampening	All
	61	N.P.N.	Street Tee 1/8 NPT	All
	62	N.P.N.	Connector Male 1/4 OD Plastic x 1/8 NPT	All

*Magnehelic is a registered trademark of Dwyer® Instruments, Inc..

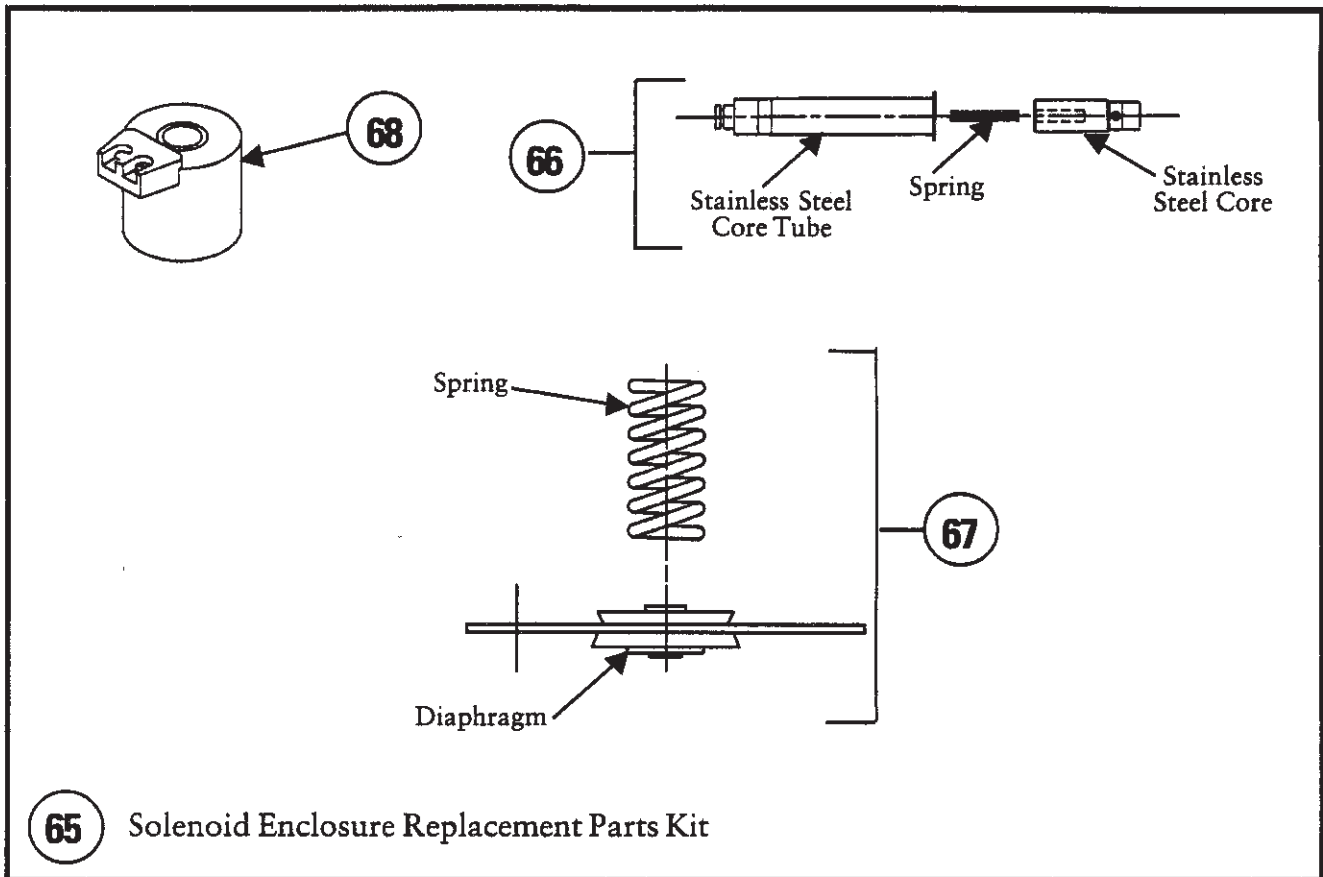

Parts Drawing 5
Solenoid Enclosure Replacement Parts Kit

Replacement Parts List

Ref. No.	Part No.	Description	Model
65	423-4072	Solenoid Enclosure Kit NEMA 4 24VDC	All
66	421-9822	Solenoid Valve Rebuild Kit	All
67	423-4073	Diaphragm Valve Rebuild Kit RCA 25	All
68	423-4074	Replacement Coil Type QT 24 VDC (3D2).....	All

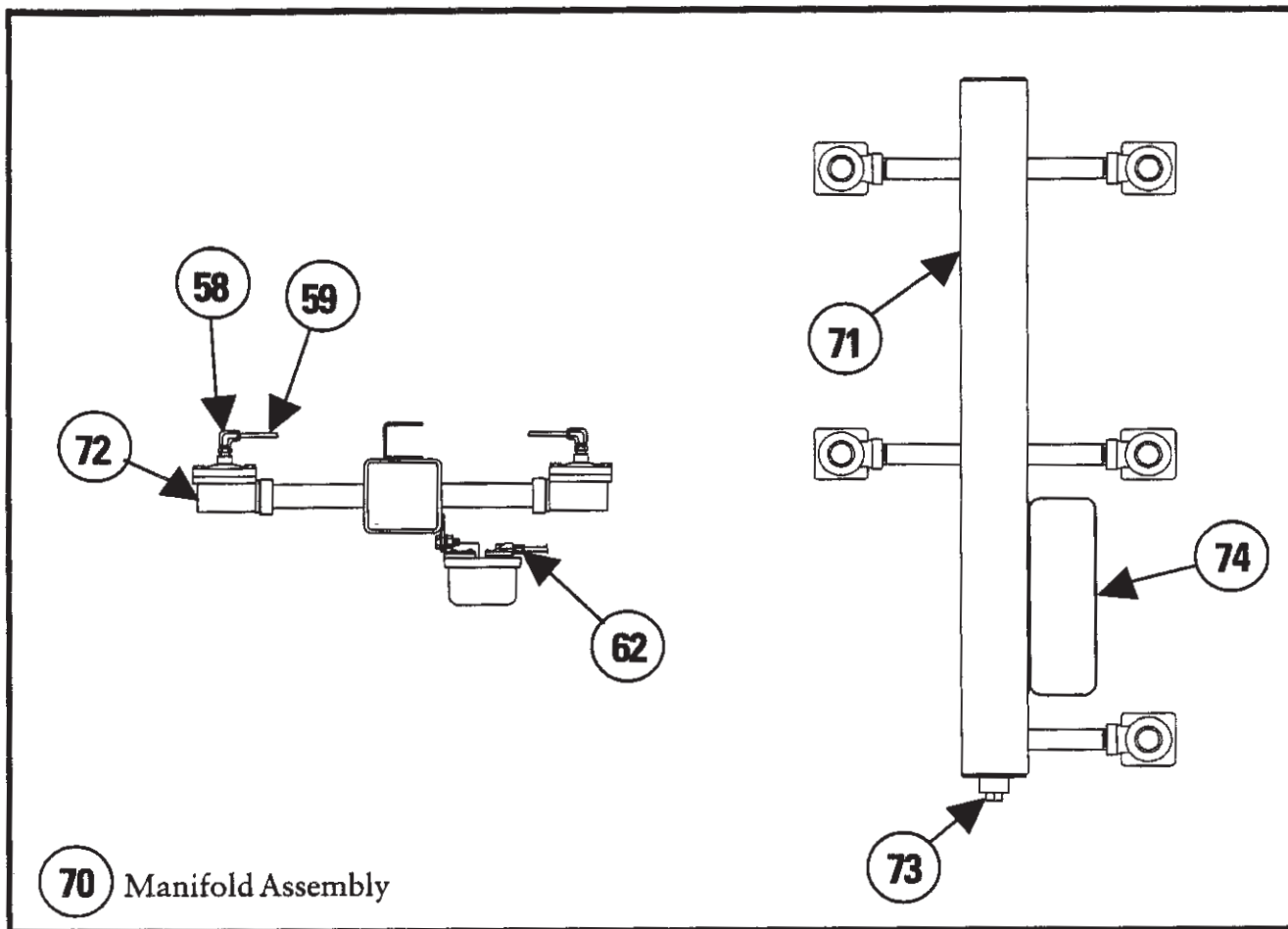

**Parts Drawing 6
Manifold Assembly LT8500**

Replacement Parts List

Ref. No.	Part No.	Description	Model
58	N.P.N.	Connector Elbow 1/4" OD x 1/8" NPT	All
59	N.P.N.	Tubing Poly 1/4" OD	All
62	N.P.N.	Connector Male 1/4" OD Plastic x 1/8" NPT	All
70	423-4051	Manifold Assembly	LT8500
71	423-4052	Manifold Weldment	LT8500
72	421-9823	Diaphragm Valve RCA 25T	All
73	N.P.N.	Plug Steel Galv 1" NPT	All
74	423-4078	Enclosure Solenoid 6 Valve 1/8" NPT NEMA 4 ...	LT8500

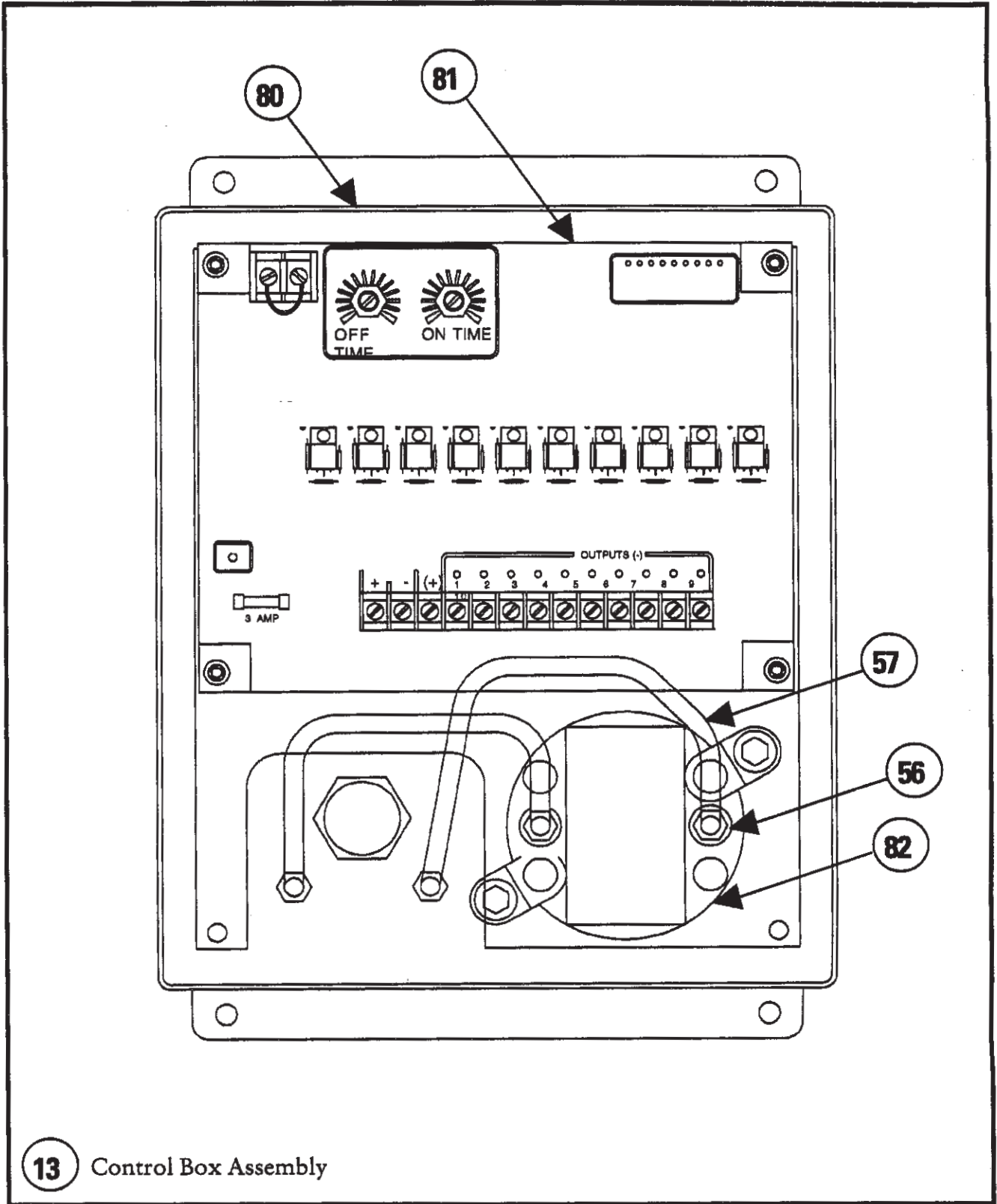

Parts Drawing 7
Control Box Assembly LT8500 & LT11,500B

Replacement Parts List

Parts Dwg. No.	Ref No.	Part No.	Description	Qty.
----------------------	------------	-------------	-------------	------

7	13	423-4058	Control Box Assembly	LT8500
	13	421-9838	Control Box Assembly	LT11,500B
	56	N.P.N.	Adapter Brass 1/8" NPT	All
	57	N.P.N.	Tubing Plastic 3/8" ID	All
	80	N.P.N.	Control Box NEMA 4 Modified	All
	81	N.P.N.	Timer 10 PIN 12-24 VDC	All
	82	N.P.N.	Switch Differential Pressure	All

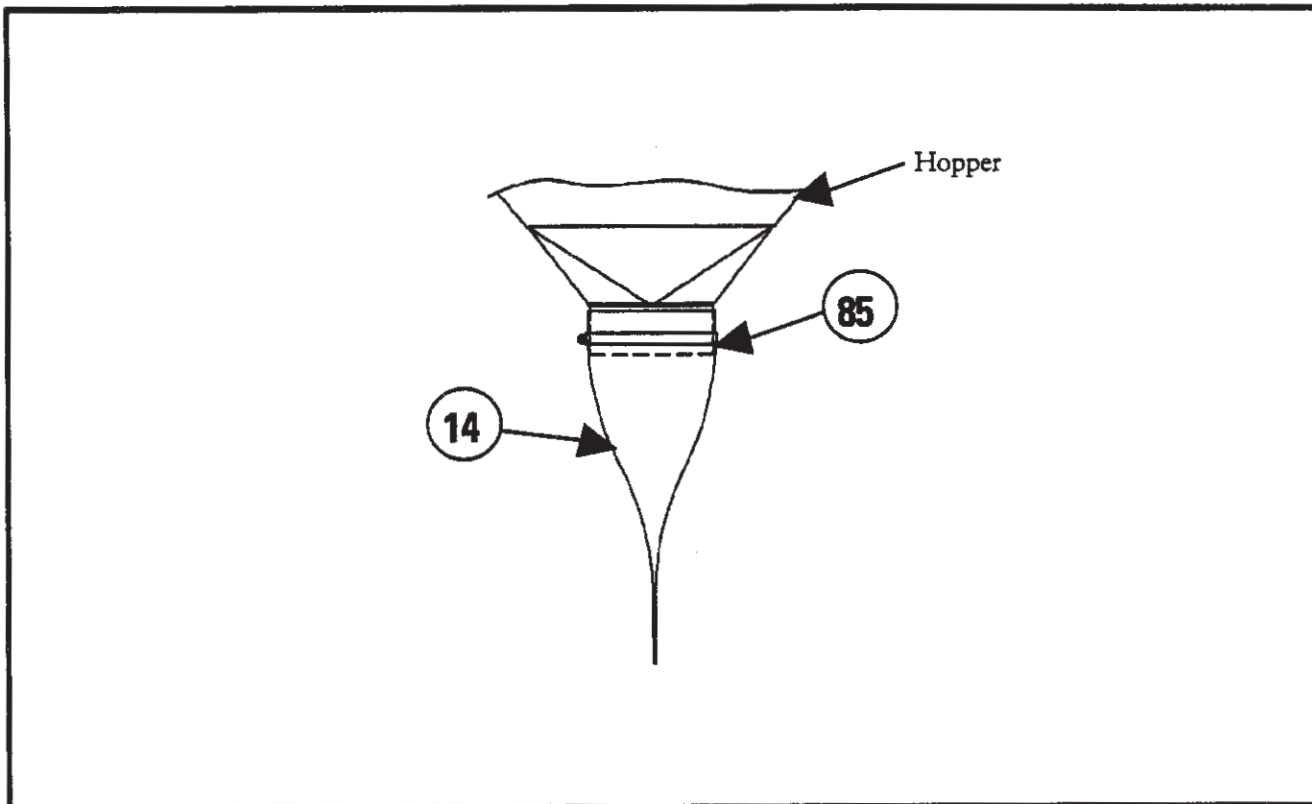

**Parts Drawing 8
Trickle Valve**

Replacement Parts List

Ref. No.	Part No.	Description	Model
----------	----------	-------------	-------

14	423-4059	Valve Trickle	All
85	N.P.N.	Hose Clamp	All

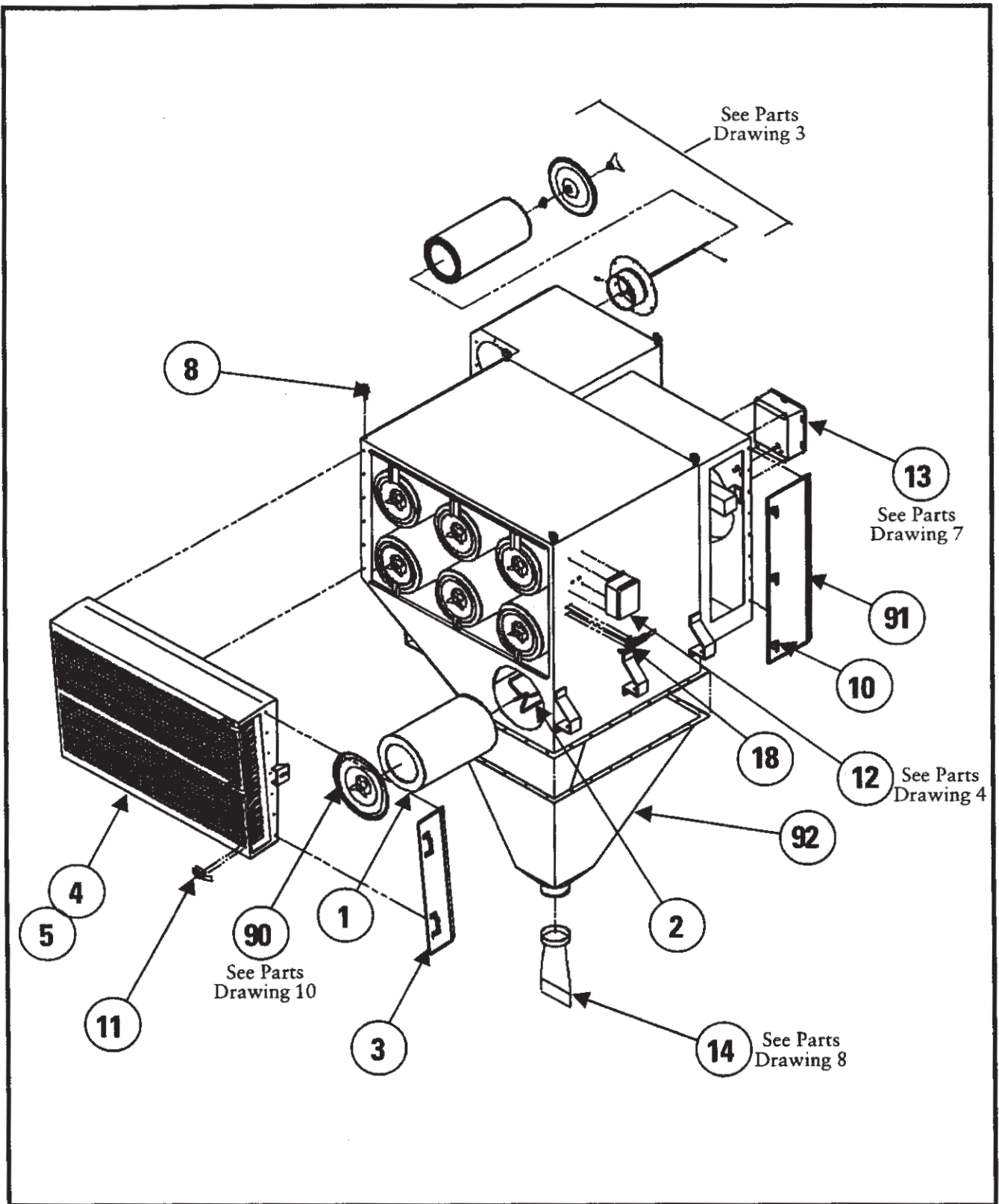

Parts Drawing 9
LT11,500B Cartridge Filter System

Replacement Parts List

Parts Dwg. No.	Ref No.	Part No.	Description	Qty.
----------------------	------------	-------------	-------------	------

9	1	421-9820	Filter Element Blue Ultra-Web® II.....	All
	2	423-4049	Yoke Weld	All
	8	N.P.N.	Bolt Eye Shldr 1/2-13 x 1.50	All
	10	423-4055	Latch Vise Action	All
	12	423-4061	Pressure Monitoring Assembly	All
	13	421-9838	Control Box Assembly	LT11,500B
	14	423-4059	Trickle Valve	All
	15	423-4060	Cover Knob Assembly	All
	18	423-4064	Clamp Modified	All
	90	423-4062	Access Cover Assembly Top	LT11,500B
	90	423-4063	Access Cover Assembly Bottom	LT11,500B
	91	423-4065	Cover Weld CA Plenum without Holes	LT11,500B
	92	423-4066	Hopper Weld	LT11,500B
	93	N.P.N.	U-Bolt Rubber Coated 1/4-20 x 1	LT11,500B

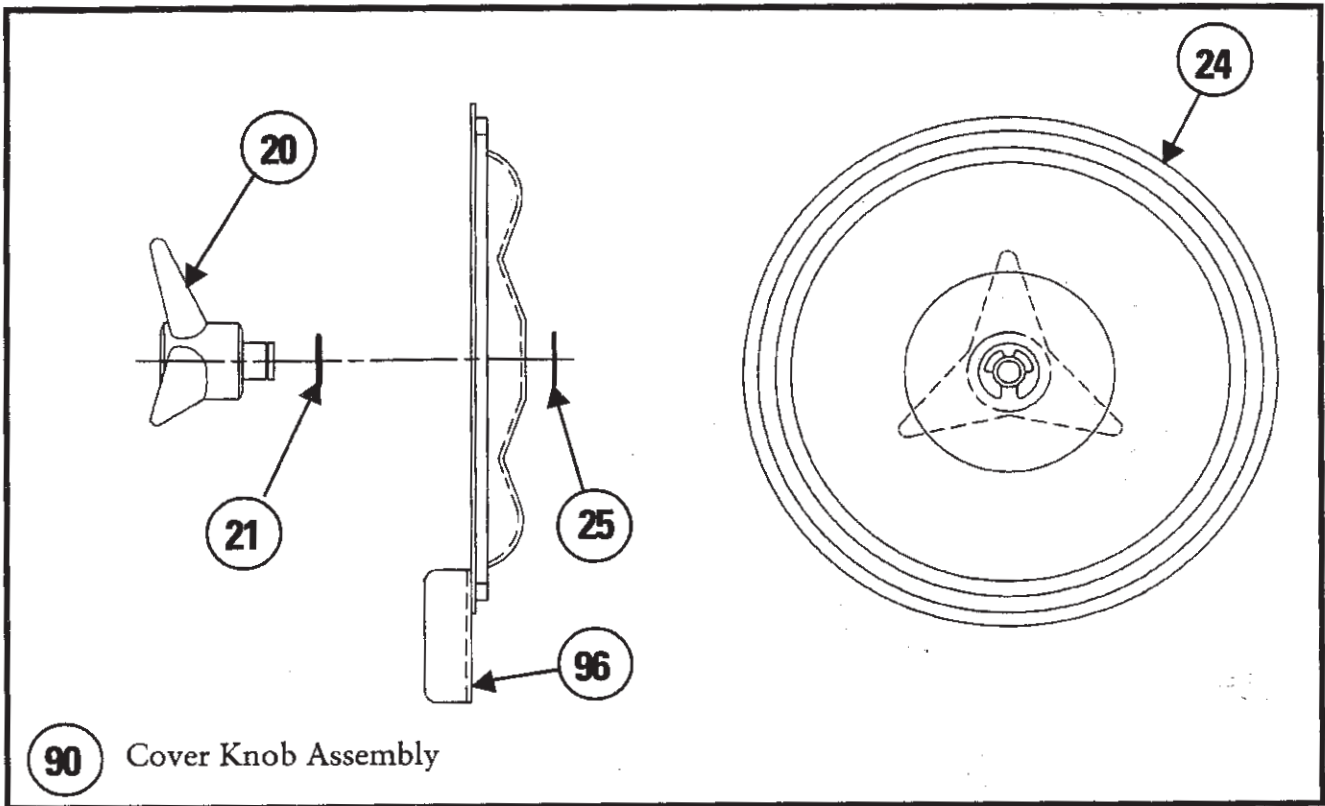

Parts Drawing 10
Access Cover Assembly Top/Bottom LT11,500B

Replacement Parts List

Ref. No.	Part No.	Description	Model
20	422-3086	Knob 3 Lobe	All
21	423-4067	Gasket Washer .81" ID	All
24	423-4070	Gasket 3/8" x 1/2" - 10.12" ID	All
25	423-4071	Clip .668" ID	All
90	423-4062	Access Cover Assembly Top	LT11,500B
90	423-4063	Access Cover Assembly Bottom	LT11,500B
96	N.P.N.	Access Cover Weld Top	LT11,500B
96	N.P.N.	Access Cover Weld Bottom	LT11,500B

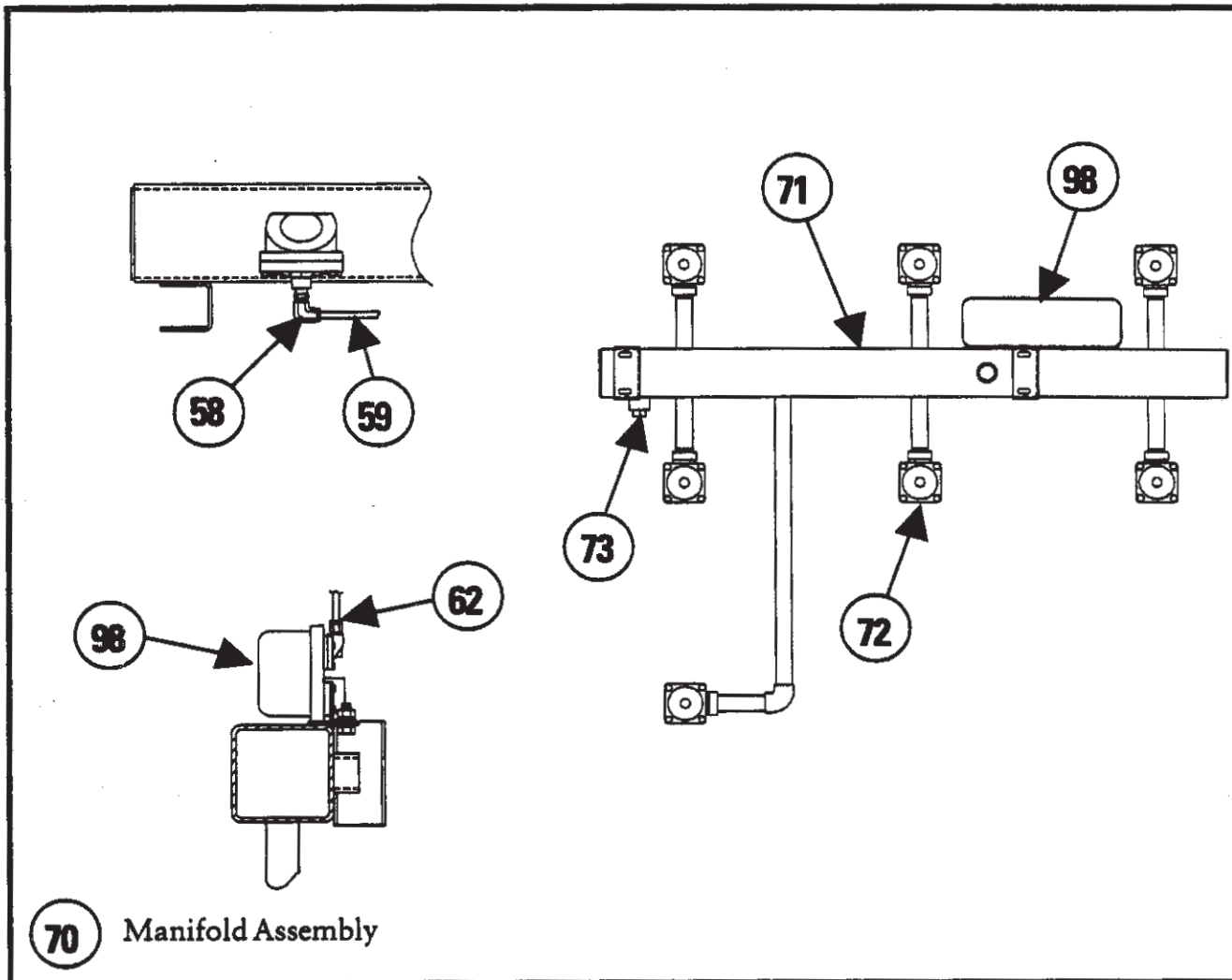

**Parts Drawing 11
Manifold Assembly LT11,500B**

Replacement Parts List

Ref. No.	Part No.	Description	Model
58	N.P.N.	Connector Elbow 1/4" OD x 1/8" NPT	All
59	N.P.N.	Tubing Poly 1/4" OD	All
62	N.P.N.	Connector Male 1/4" OD Plastic x 1/8" NPT	All
70	423-4081	Manifold Assembly	LT11,500B
71	423-4082	Manifold Weldment	LT11,500B
72	421-9823	Diaphragm Valve RCA 25T	All
73		Plug Steel Galv 1" NPT	All
98	423-4077	Enclosure Solenoid 7 Valve 1/8" NPT NEMA 4	LT11,500B

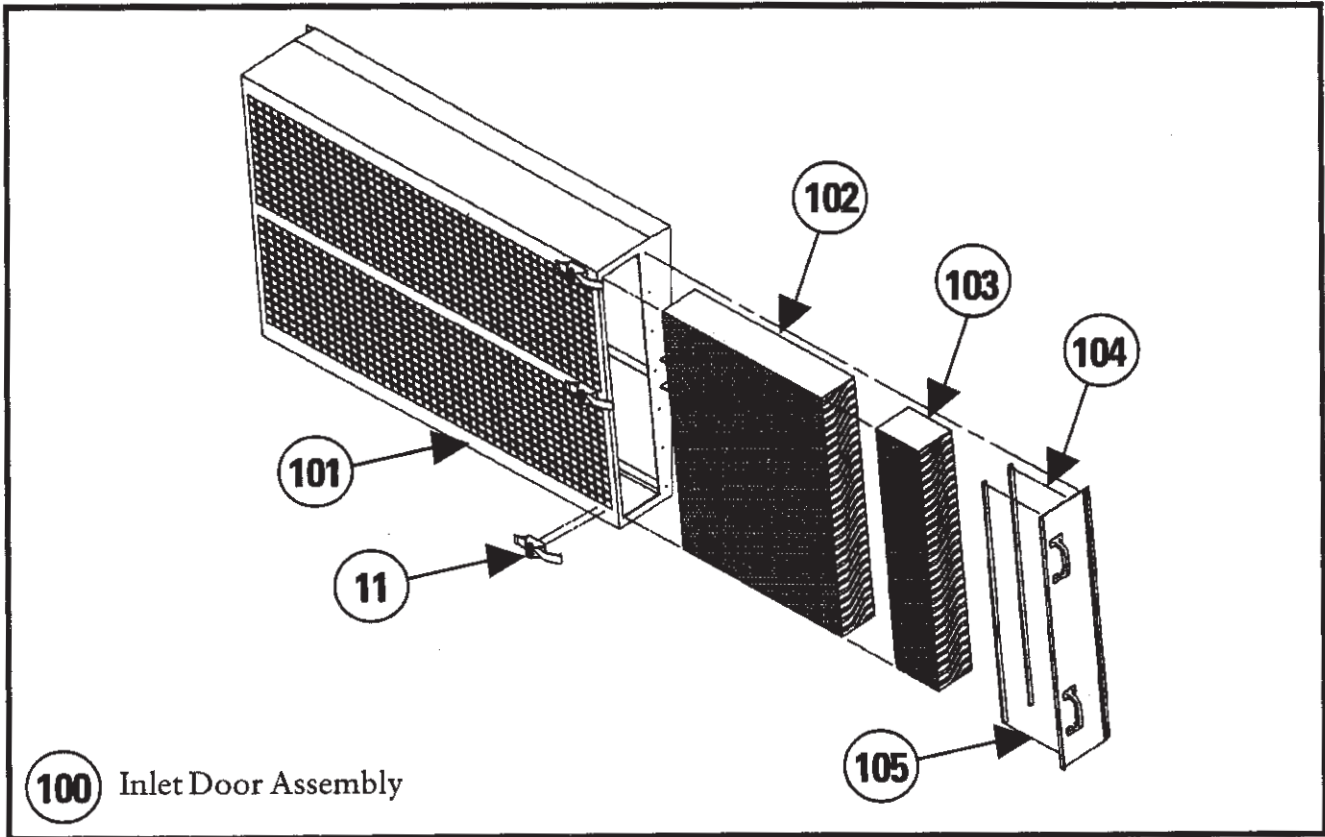

**Parts Drawing 12
Inlet Door Assembly**

Replacement Parts List

Ref. No.	Part No.	Description	Model
----------	----------	-------------	-------

11	423-1033	Latch Over Center	All
100		Inlet Door Assembly	LT8500
100	423-4075	Inlet Door Assembly	LT11,500B
101		Inlet Door Weld	LT8500
101	423-4076	Inlet Door Weld	LT11,500B
102		Drift Eliminator Intlk	LT8500
102	422-7743	Drift Eliminator Intlk 25.25 x 36.00	LT11,500B
103	422-7744	Drift Eliminator Intlk 6.79 x 36.00	LT11,500B
104	423-4079	Access Door Weld Mist Eliminator	LT11,500B
105	423-4080	Gasket Urethane 1/2 x 1/2	LT11,500B

Notes

Notes



LeTourneau, Inc.

LeTourneau Parts Sales

Phone: 903-236-6570

Fax: 903-236-6552

PARTS ORDERING INFORMATION

When ordering parts, give model number
and serial number, part number, description
and quantity of parts desired

IOM-75433-00
February 2000
© Copyright 2000 LeTourneau
Printed in USA

LeTourneau, Inc. © 2000